

eb104.ru™

User's manual

Transistor linear VHF power amplifier 500 W

Contents

Introduction	3
Precautions for use with the	3
Functional features of the amplifier	4
Characteristics of the amplifier	4
Front Panel Description	6
Description of the rear panel	6
Connecting the control cable	7
Power Amplifier Protection Circuits	7
Application	9
Warranty	11

Introduction

Before using the Power Amplifier, carefully read this manual and other documentation that came with your amplifier. This will allow you to reduce the risk of failure of this product.

EB500 is a transistor linear VHF power amplifier designed for use with amateur radio stations. Distinctive features of the amplifier:

- instant availability for operation;
- compact size, light weight;
- no need to replace components due to wear;
- increased service life;
- lack of high voltage in the high-frequency part;
- the ability to automate operation.

Operating Precautions

For the power amplifier to work properly, you must follow some precautions:

- **The operation of the amplifier with an appropriate electrical grounding system is required;**
- If possible, organize the chassis grounding of the radio-transmitting device, which will ensure the most efficient and stable operation of all the equipment of the amateur station, and will reduce the level of possible interference and RF interference; ground all station equipment to a common ground.
- If the protection systems of the amplifier are repeatedly activated, it is necessary to stop the operation of the amplifier until the causes of the emergency shutdown are eliminated. Multiple tripping of protection systems can damage expensive LDMOS transistors;
- Do not drop, or damage the case, or allow foreign objects inside - this may lead to the failure of the electronic components of the power amplifier.
- Do not operate the power amplifier with the covers removed to avoid overheating of the device. The absence of covers disrupts the cooling system.

Functional Features of the Amplifier

The built-in potentiometers in the protection circuit and the BIAS voltage control circuit are set to the correct position during setup and testing of the equipment. Any change in the position of these potentiometers will result in the need to reconfigure the amplifier using accurate measuring instruments.

Before operating the power amplifier, it is necessary to connect a load equivalent of 50 ohms, minimum 500 watts or a matched antenna with known low SWR to the output antenna connector. The operation of the amplifier without load negatively affects the operation of the output RF transistors.

To obtain an output power of 500 watts, the input power level should be no more than 50 watts. It is not recommended to use transmitters with an output of more than 50 watts with an amplifier.

The amplifier is designed for an impedance of 50 ohms. If the antenna-feeder devices are matched to a resistance of 50 Ohms, and the SWR on all operating ranges does not exceed the value of 1.5 to 1, then the amplifier can be operated without additional coordination. If the SWR is greater than 1.5 to 1, then the use of additional matching devices is recommended.

In the output stage of the power amplifier, two high-quality LDMOS transistors MRF300AN and MRF300BN are used.

The rated power of each MRF300 transistor is 300 watts. The use of high-linear transistors also allowed to obtain IMD3 -30 dBc.

The process of switching the transmit-receive in the amplifier is provided by coaxial relays controlled by a digital sequencer on the TINY13A microprocessor, which allows you to control an external LNA, as well as control the transceiver by the TX INHBIT command.

The power amplifier is equipped with special high-speed protection circuits. For example, from excess of output power, high value of SWR in the antenna, high drain current of output transistors and overheating.

To control the operating parameters of the power amplifier, a digital measuring device is used, on which the output power level and the SWR value are displayed.

Frequency range	144-148 MHz
Types of radiation	SSB, CW, DIGI, RTTY
Input power	50 watts
output power	500 W (SSB / CW, DIGI, RTTY)
Maximum SWR in the antenna	1.5: 1
Supply voltage	30 ... 53V
Consumption current	15A max (53V each)
Input impedance	50 ohm (unbalanced)
Output impedance	50 ohm (unbalanced)
Input / output connectors	UHF SO-239
Amplifier circuit	push-pull class AB
Output Stage Transistors	MRF300AN, MRF300BN
Dimensions - W x H x D (mm)	290x140x205
Weight (gr.)	3900

Front Panel Description

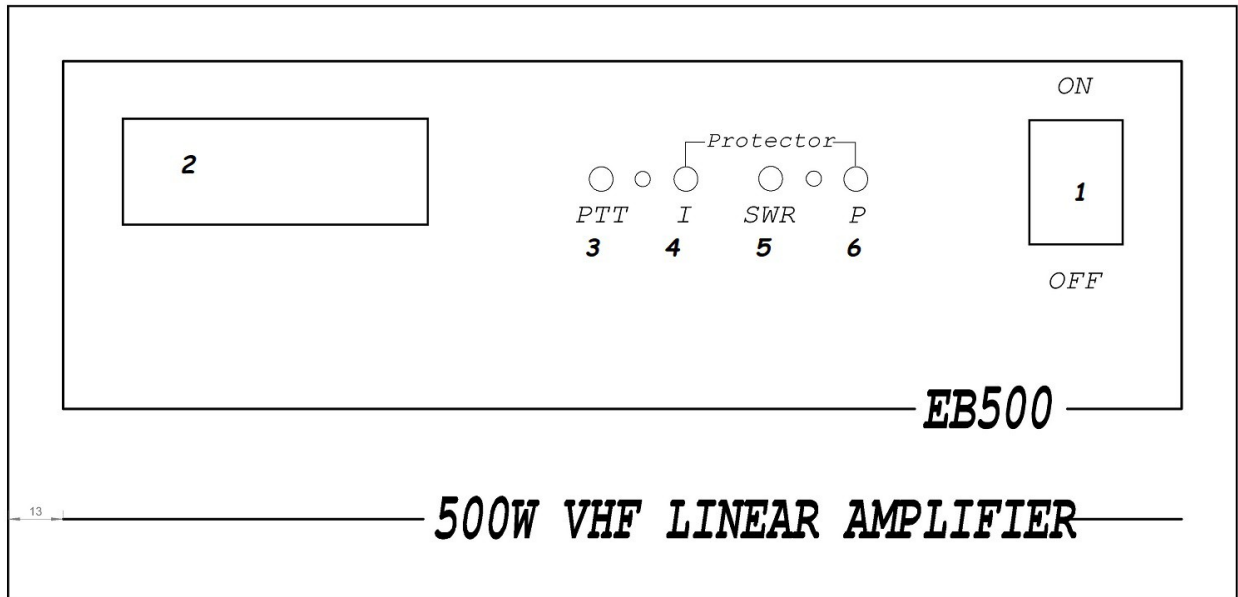

1. Key switch on and off the power amplifier.
2. Digital power indicator and SWR.
3. Green LED - indicates transmission mode.
4. Over current protection indicator
5. Protection indicator for excess SWR
6. Protection indicator for exceeding the maximum permissible output power

Turn the amplifier off and on again to reset the protection circuit.

Back panel description

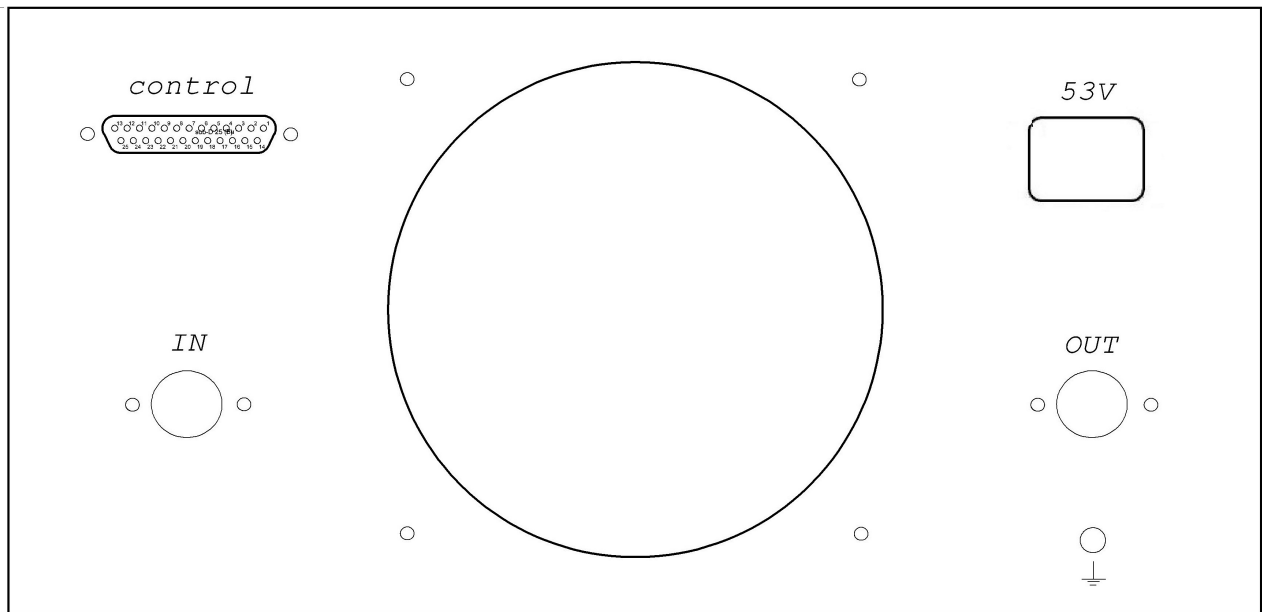

OUT - RF connector for connecting the antenna.

CONTROL - connector for PTT signal.

IN - connector for connecting a coaxial cable from the transceiver.

53V - connector for connecting a 30-53V power supply.

Control cable connection:

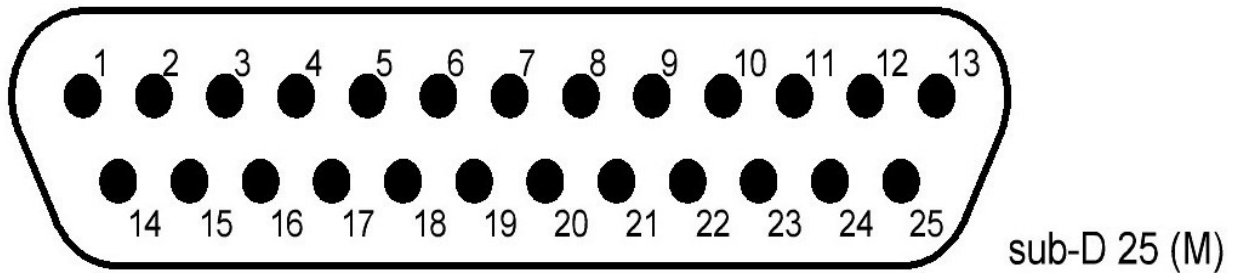

5 pin – LNA Control

15 pin - PTT, connection to the housing enables transmission mode

17 pin – TX INHBIT

22-25 pin - GND, common wire.

Power Amplifier Protection Circuits

1. Overheat protection.

If the temperature of the transistor case exceeds + 70 ° C, the bimetallic thermal switch located on the transistor case will be triggered and transmission becomes impossible, until it cools down to + 65 ° C.

2. Protection against exceeding the maximum permissible output power.

If the output power level exceeds the permissible threshold, a protection will be activated that disconnects the power from the output transistors. The P LED lights up on the front panel. A power cycle is required to reset the protection.

3. Protection against high SWR.

If the SWR in the load exceeds the value of 1.5: 1, then the protection system will trigger. The SWR LED on the front panel lights up. To reset the protection, turn off the power. In case of protection operation, we recommend checking the SWR antenna and feed line. Insure feed line and connectors are adequate for handling 500 watts

4. Protection against exceeding the maximum permissible current.

If the current value of the output transistors exceeds the permissible threshold, a protection will be activated that disconnects the power from the output transistors. The LED I on the front panel lights up. To reset the protection, turn off the power.

Application

✓ VHF power amplifier 500W output 144-148 MHz MRF300 input power 50W

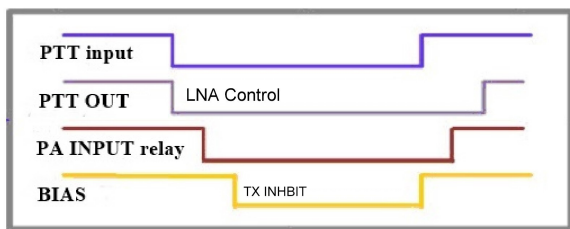
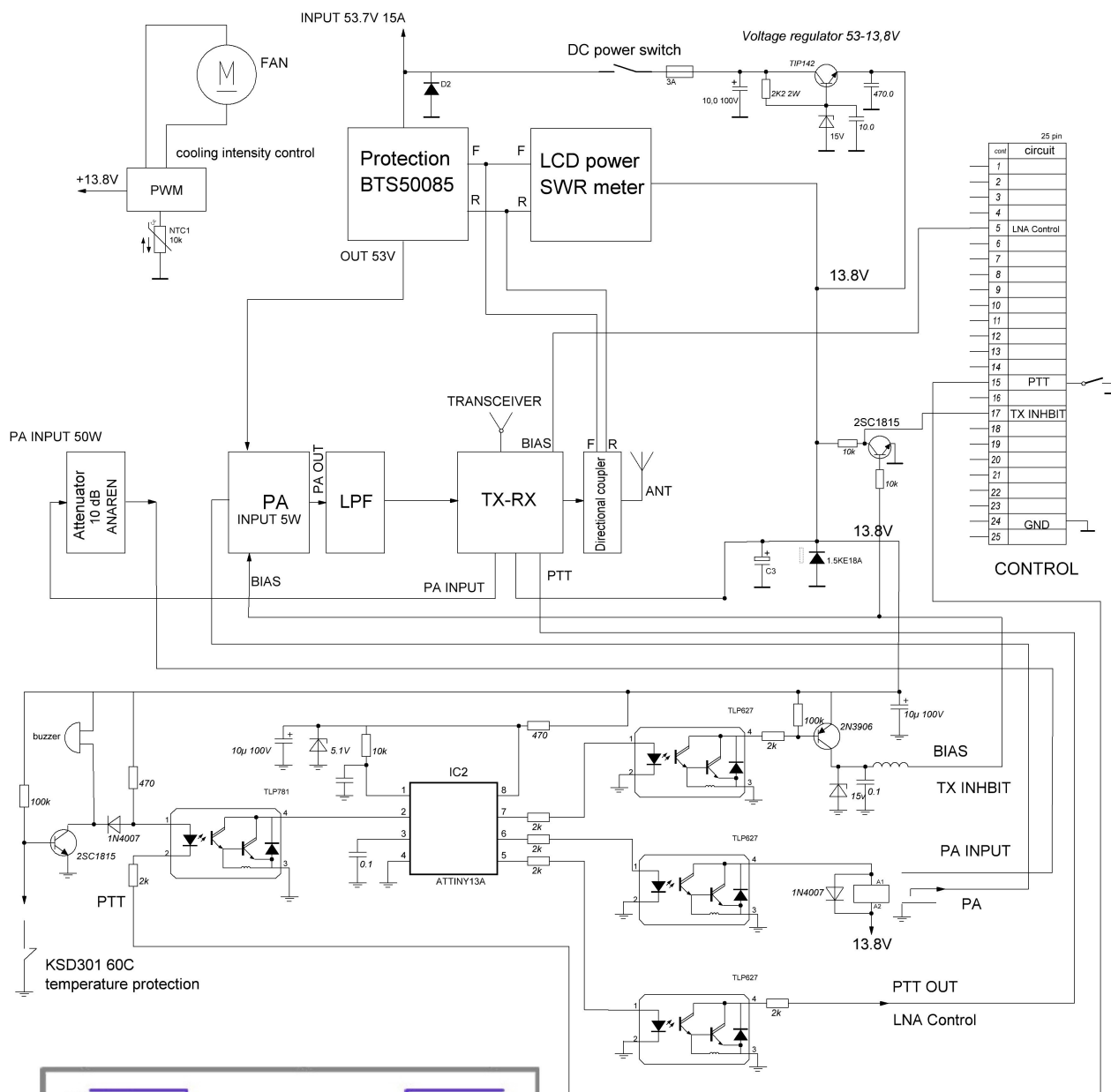

each interval is 50 milliseconds

✓ PA 144-148 MHz 500W output

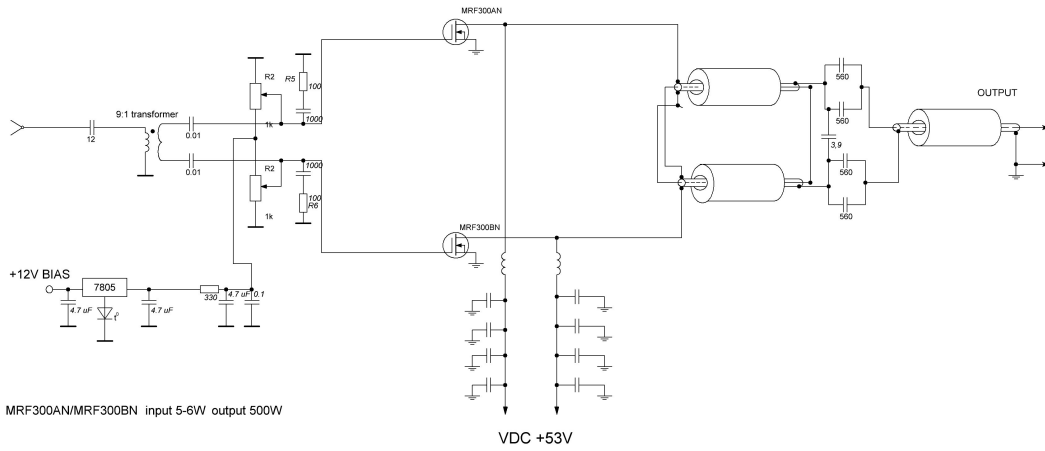

✓ Low pass filter 144-148 MHz

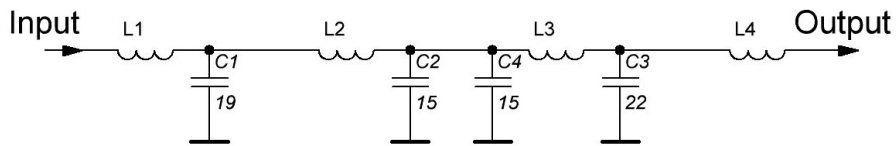

✓ Directional coupler bridge

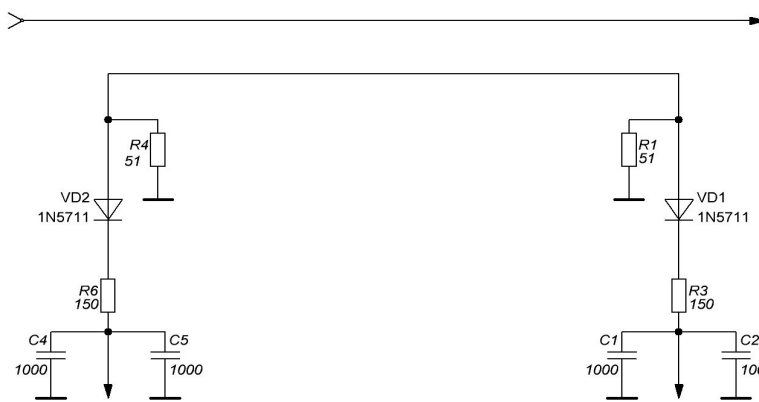

Smart High Current DC Switch with protection triggers for power amplifiers

(SWR, the current, maximum output power)

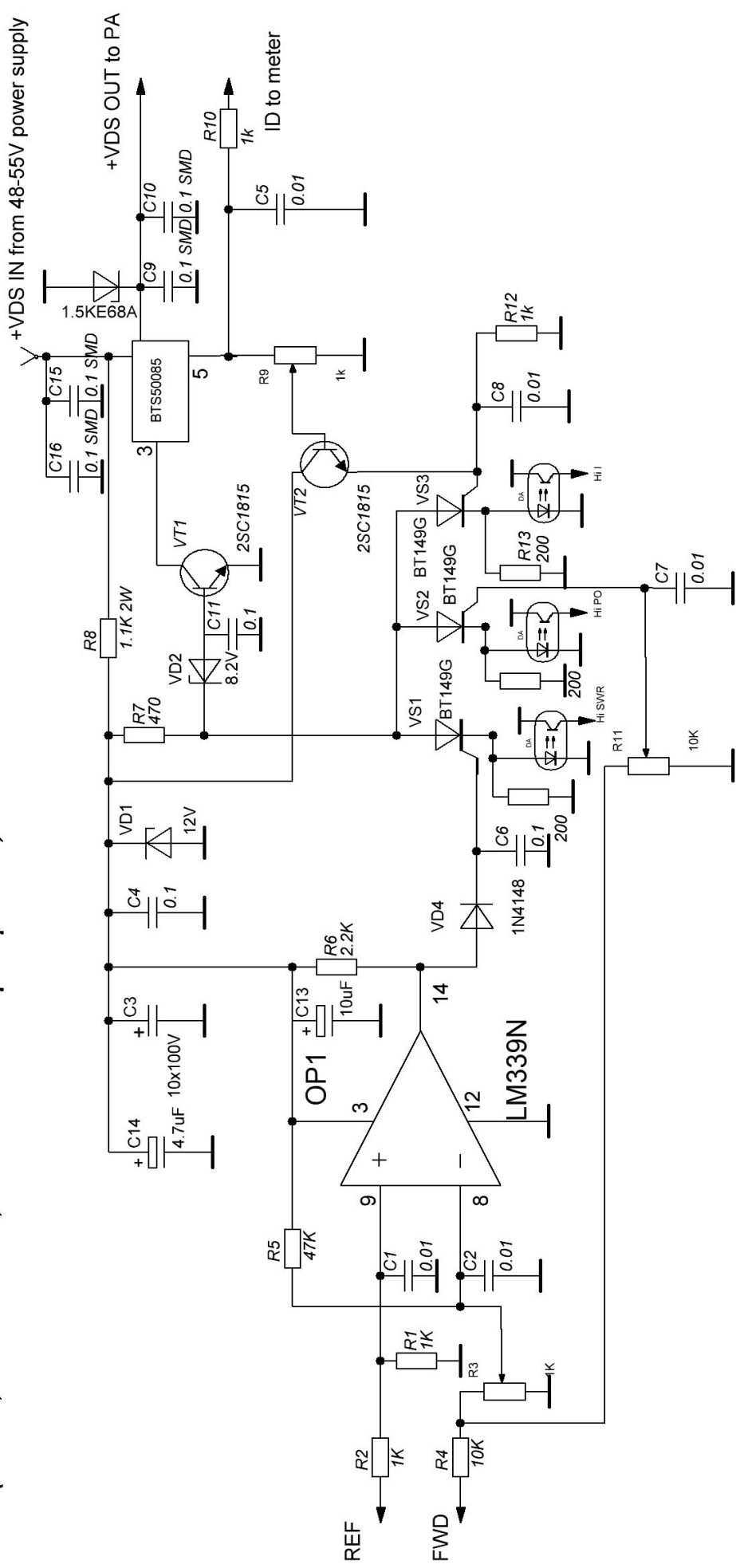

✓ VHF 144-148 MHz TX-RX unit (PTT board)

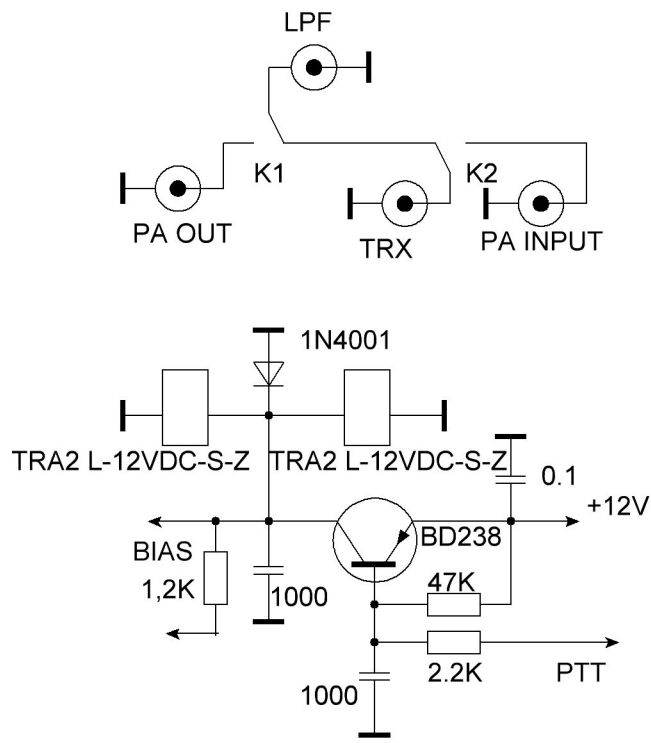

Typical circuit for switching on an external LNA (not included in the power amplifier)

